

G80c - 12V CONTINUOUS DIESEL TRANSFER PUMP

CONTINUOUS DUTY CYCLE TO KEEP OPERATIONS MOVING

TECALEMIT's G80c 12V Diesel Transfer Pump is the latest continuous duty pump offering in our portfolio. The G80c is a fully mechanical pump, maintaining its flow rate without the use of electronics. This pump features heavy duty construction, made of cast iron, and weighing just over 30 lbs.

The G80c can run for hours without variations in flow rate or internal temperature. This self-priming pump has proven itself to stand the test of time.

The G80c 12V Continuous Duty Cycle Diesel Transfer Pump is ideal for tank, tote, or drum applications.



TECHNICAL SPECIFICATIONS & FEATURES

100% continuous duty cycle	
Self suction Self-priming Self-adjusting blades	
Recirculation bypass	
Tropicalized for warm & humid climates	
Anti-rust treatment	
Self-ventilated, dust protected motor	
IP-55 protection	
Suction lift:	8.9 ft.
Max. delivery:	65.6 ft.
Free flow:	18-22 gpm
Motor:	0.37 kW
Rotational speed:	1500 rpm
Inlet:	1" NPT connection
Outlet:	1" NPT connection
Mounting flange connection:	2" NPT
Cable length (includes alligator clips):	9.8 ft.
Dispense hose:	13 ft.
Weight:	45 lbs.
Dimensions (W x D x H):	13.8" x 6.5" x 6.9"

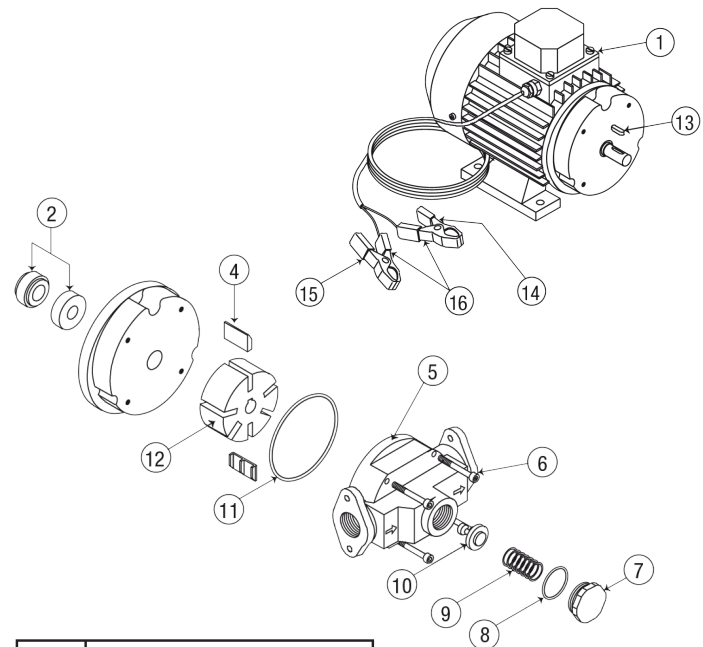

No.	DESCRIPTION
1	12 VDC MOTOR
2	MECHANICAL SEAL
4	6-BLADE SET
5	PUMP BODY
6	M-6x55 mm DIN.912 ZINC-PLATED SCREW
7	BYPASS PLUG
8	30x3 mm NBR BYPASS JOINT
9	BYPASS SPRING
10	BYPASS VALVE
11	85x4 mm JOINT
12	D.16 mm ROLLER
13	5x5x20 mm COTTER PIN
14	BIG RED CLAMP CASE
15	BIG BLACK CLAMP CASE
16	BIG METAL CLAMPS

PART

DESCRIPTION

US109900005

G80c CONTINUOUS DUTY CYCLE PUMP KIT

